



DANGER
COMBUSTIBLE
DUST
EXPLOSION HAZARD

Ex CAT 2

DYNACO S-539 Cat.2 Atex Compact

Push-Pull
gear driven technology

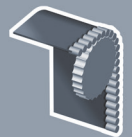

inside door

www.dynacodoor.com

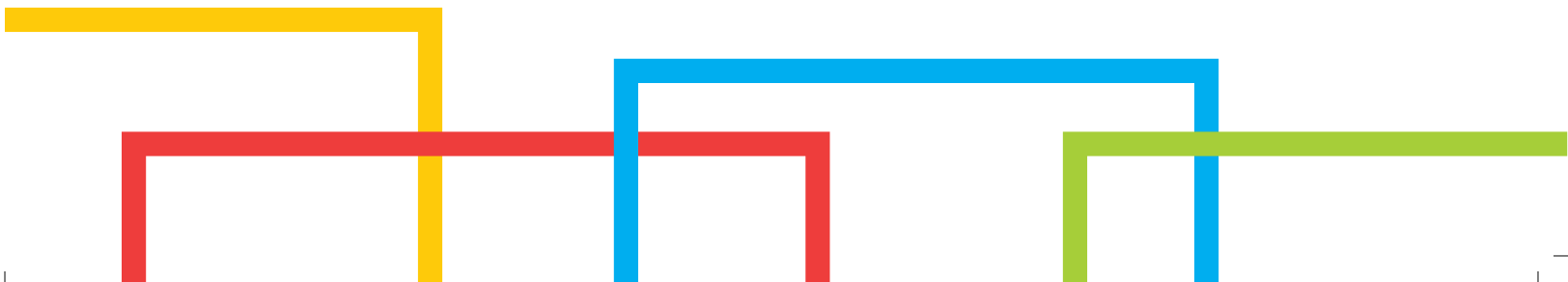

DYNACO S-539 Cat.2 Atex Compact

The Dynaco S-539 Cat.2 Atex Compact is specifically designed for inside applications in explosion sensitive environments, category 2. Officially approved by Apragaz notified body for use in potentially explosive atmospheres.

All metal parts are stainless steel, non-metallic parts are composed of antistatic or electrical conductive materials, thus avoiding the build up of static electricity that could generate sparks.

Operating speed and perfect sealing properties improve your traffic flows and provide employee comfort, environmental control and savings on energy costs.

Fully self-reinserting, the Dynaco S-539 Atex Cat.2 Compact will automatically reinsert itself in its side guides when the curtain is accidentally hit.

- **HIGH SPEED OPERATION:**
Maximum speed 1 m/s.
- **PATENTED "PUSH PULL" TECHNOLOGY:**
Unique door drive system.
- **CRASH FORGIVING AND SELF-REINSERTING WITHOUT INTERVENTION:**
The curtain automatically reinserts itself when dislodged. No repair costs, no production downtime.
- **USER SAFETY:**
Flexible curtain without rigid elements.
- **ADVANCED DRIVE:**
Frequency driven motor and encoder for smooth operation. Wearable elements are reduced to a minimum.
- **DYNALOGIC CONTROL BOX:**
User-friendly control box with self-diagnosis.
- **CONFORM TO EN13241-1**
- **CONFORM TO DIRECTIVE 2014/34/EU**
Ex II 2 G/D
Ex h T4 135°C
Ex db ia e IIC T4 EPL Gb
Ex tb ia IIIB 135°C EPL Db
CE 0029 APRAGAZ 17 ATEX 0157 X
T ambient -10°C to 55°C



All synthetic parts in antistatic material



Complete structure in stainless steel

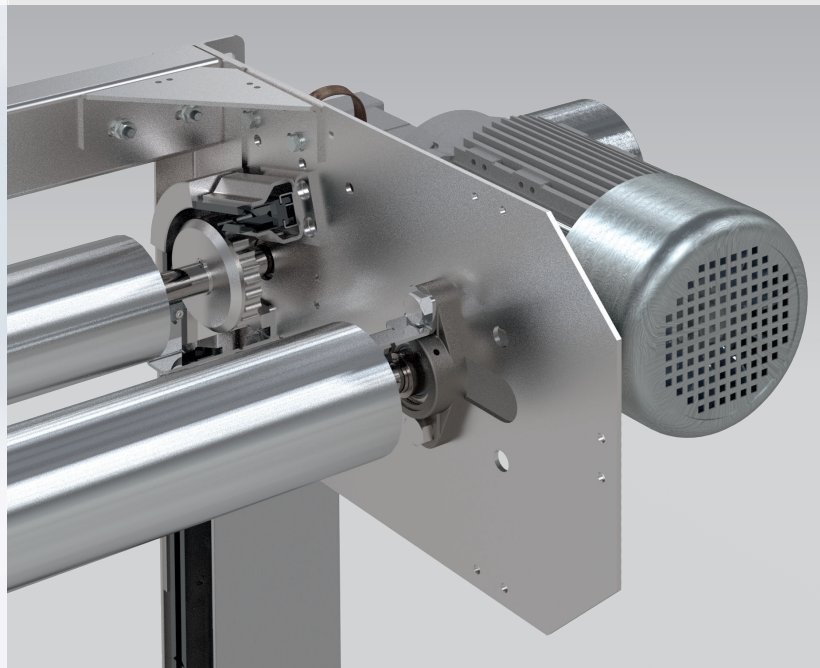

Push-Pull

gear driven technology

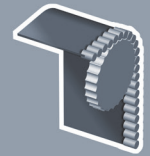

inside door

EN13241-1 STANDARDS

Standard	Ref.	Test acc.	Results
Water permeability	EN 12425	EN 12489	Class 1
Wind load	EN 12424	EN 12444	Class 1
Wind permeability	EN 12426	EN 12427	Class 1*
Safe openings	EN 12453	EN 12445	Pass
Mechanical resistance	EN 12604	EN 12605	Pass
Unintended movements	EN 12604	EN 12605	Pass
Thermal transmittance	EN 12428	EN 12428	6,02 W/m ² K
Performance (cycles)	EN 12604	EN 12605	NPD

* Valid for a door of 3500 x 3500mm

Explosion groups	Temperature class					
	T1	T2	T3	T4	T5	T6
Min. ignition temp. or max. surface temp.	450 °C	300 °C	200 °C	135 °C	100 °C	85 °C
I (Mining)	Methane					
IIA	Acetone Ammonia Benzene Acetic acid Ethane Ethyl acet. Methane Methanol Naphthalene Phenol Propane	i-Amylac- etate n-Butane n-Butane alcohol	Benzines Diesel fuels Fuel oils n-Hexane	Acetaldehyde		
IIB	Town gas	Ethylene Ethylene oxide	Hydrogen sulphide	Ethyl ether		
IIC	Hydrogen					Carbon disul- phide

CHARACTERISTICS

Max. dimensions	W 5.500 mm x H 5.500 mm
Opening speed Closing speed	Maximum 1 m/s 1 m/s
Structure	Stainless steel: 80 x 40 x 3 mm.
Drum	Stainless steel - Ø 102 x 1.2 mm.
Side guides	Reinforced antistatic polyethylene (PE-UHMW1000 carbon black) on springs.
Motor	4 poles, without brake. Ex d Power 1,5 kW - IP rating: IP 66
Control box	DYNALOGIC 5 (500x500x250mm) provided with: circuit breaker, general divider, adjustable timer, push button for opening and reset, emergency stop and Ex i switching amplifier. IP rating: IP 65. Frequency inverter. Always to be installed outside the danger zone.
Standard detectors	Ex ia infrared barrier: 300 mm from the floor. Bottom edge detection via intrinsic safety barrier
Power supply Frequency	Single phase 230V - 18 A Frequency: 50-60 Hz
Available colours comparable with:	Black RAL9005  (Actual colour may deviate. Colour sample availa- ble upon request)

Atex motor, gearbox and encoder

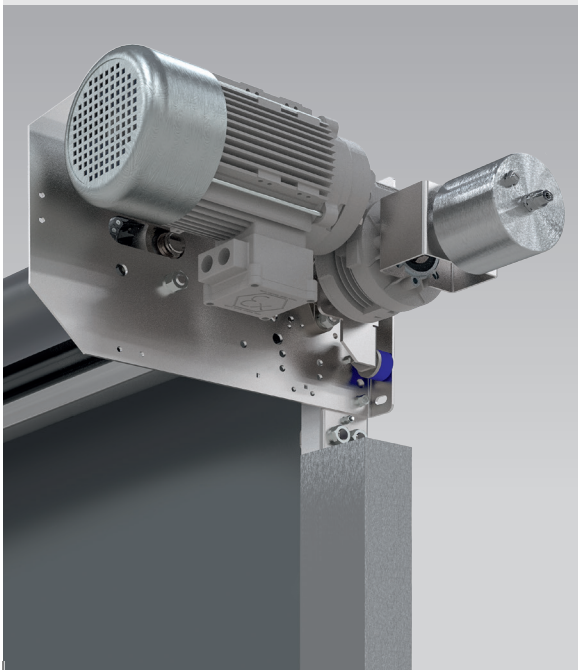

Bottom edge detection via intrinsic safety barrier

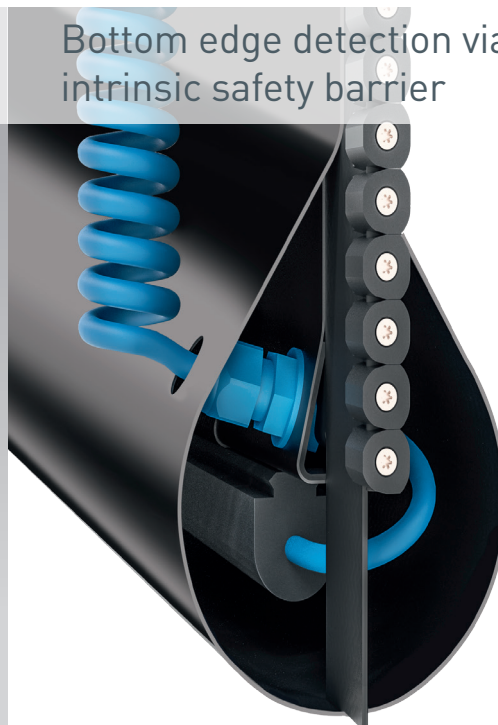

Standard earthing kit



Dimensions and installation requirements Dynaco S-539 Cat.2 Atex Compact

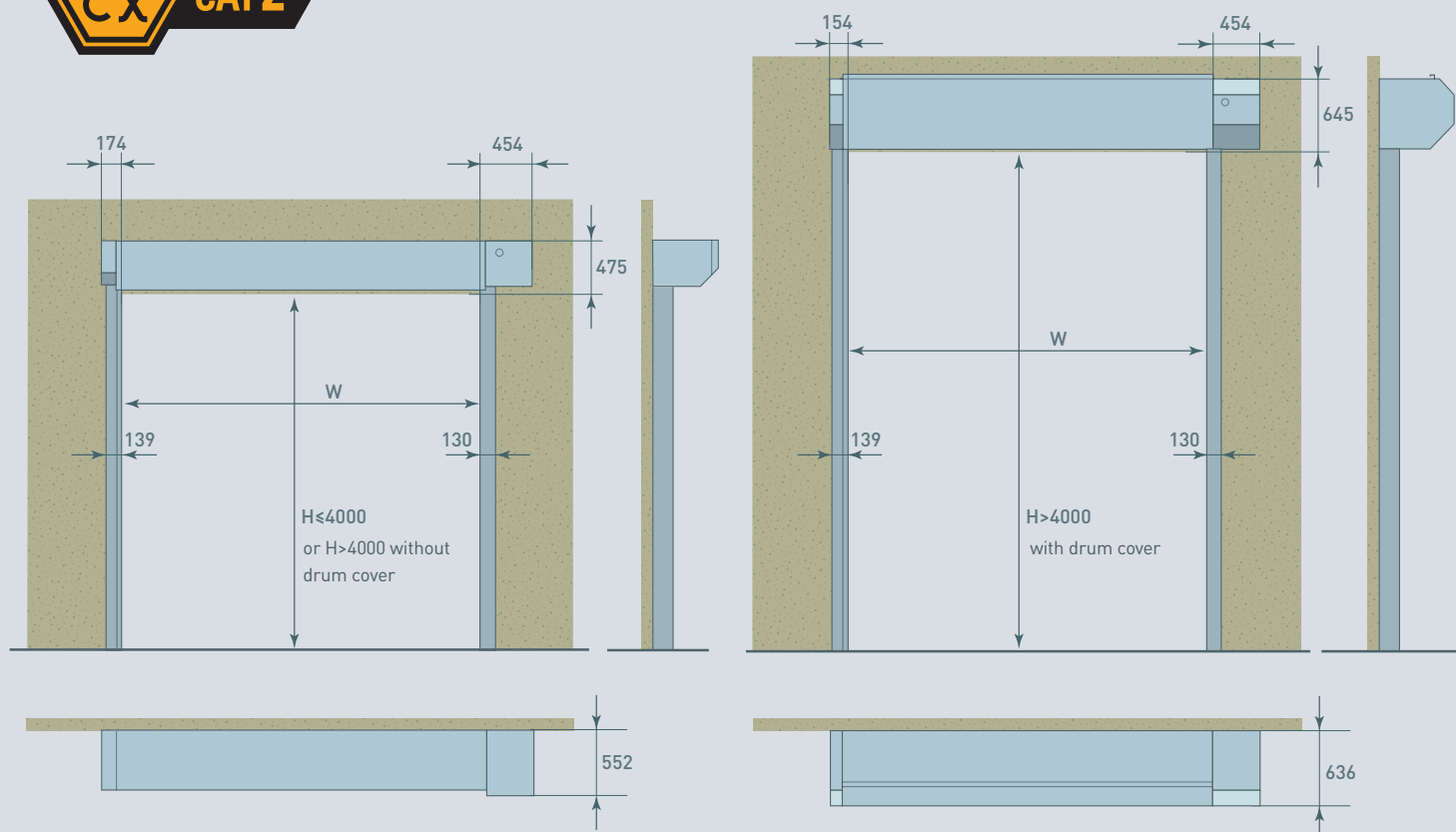

All indicated dimensions are net: the space necessary for mounting and maintenance has to be provided. Reduced dimensions: upon request.

REMARK: Based on the risk analysis of the environment, extra push buttons, detectors and covers might be required.

© Entrematic Group AB – 2017

Entrematic offers a comprehensive range of products for industrial, commercial, institutional and residential applications, including sectional doors, loading dock equipment, high-performance doors, residential garage doors, pedestrian doors, gates and barriers, and automation and operators. Built on nearly 200 years of accumulated expertise, Entrematic aims to be the most dynamic, innovative company in the entrance automation industry, and the best partner for dealers and installers. Our well-known brands include Normstahl, Dynaco, Ditec, EM and Nergeco.

Entrematic, Amarr, Kelly, Serco, Normstahl, Dynaco, Ditec, EM and Nergeco, as words and logotypes, are examples of trademarks owned by Entrematic Group AB or companies within the Entrematic Group.

The Dynaco products are protected by worldwide registered patents. As part of its policy of continuous product development, Entrematic Belgium NV reserves the right to change the characteristics of its products or components without prior notice.

Disclaimers:

For a correct use of our products, please refer to our manual.

Everything that is mentioned in this brochure is only valid under the terms of use in the user manual and on condition that the door was properly installed and maintained and has not undergone abuse nor neglect.

ENTREMATIc BELGIUM NV
 Waverstraat 21
 B-9310 Moorsel-Aalst (Belgium)
 Tel. +32 53 72 98 98
 Fax. +32 53 72 98 50
 info.dynaco.eu@entrematic.com
 www.dynacodoor.com

ENTREMATIc

