



DYNACO
High Performance Doors

D-211

ENTRY-LEVEL DOOR



inside door



www.dynacodoor.com

D-211 ENTRY-LEVEL DOOR



Dynaco was founded in 1987, dedicated to finding a solution for any damages caused by - and to - high-speed roll-up doors. Inspired by flexible pool covers, Dynaco designed the first ever flexible, self-repairing door, known as the Dynaco Classic.

Later, another innovation followed: Dynaco's revolutionary Push-Pull technology, marketed as the "magic" door. Thanks to this continuous innovative approach and passion, Dynaco is known for producing "the most copied door in the world".

The company distributes doors through a network of professionals only, active in 5 continents.

With its most extensive product range in the industry, Dynaco stays always AHEAD. And always operates with the end-user in mind.

To answer the needs of less demanding applications, Dynaco has developed the D-211: based on the Dynaco-invented zipper self-reinserting technology.

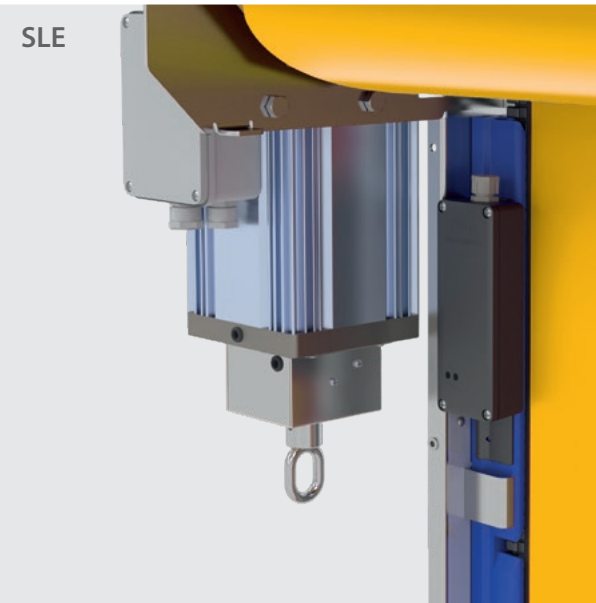

Cable-holder vibration-absorbing washers

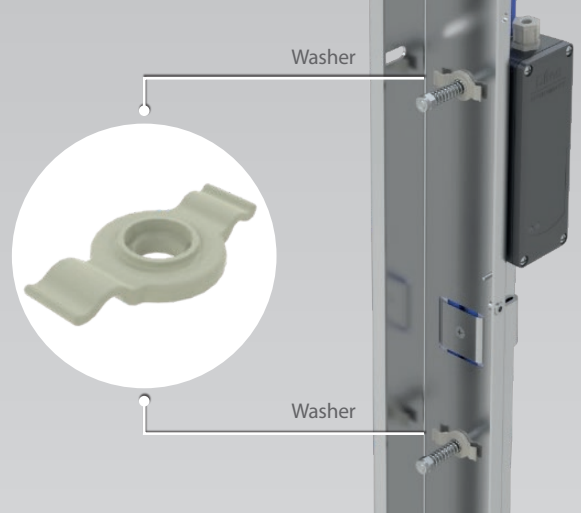

Side guide and lateral guide view

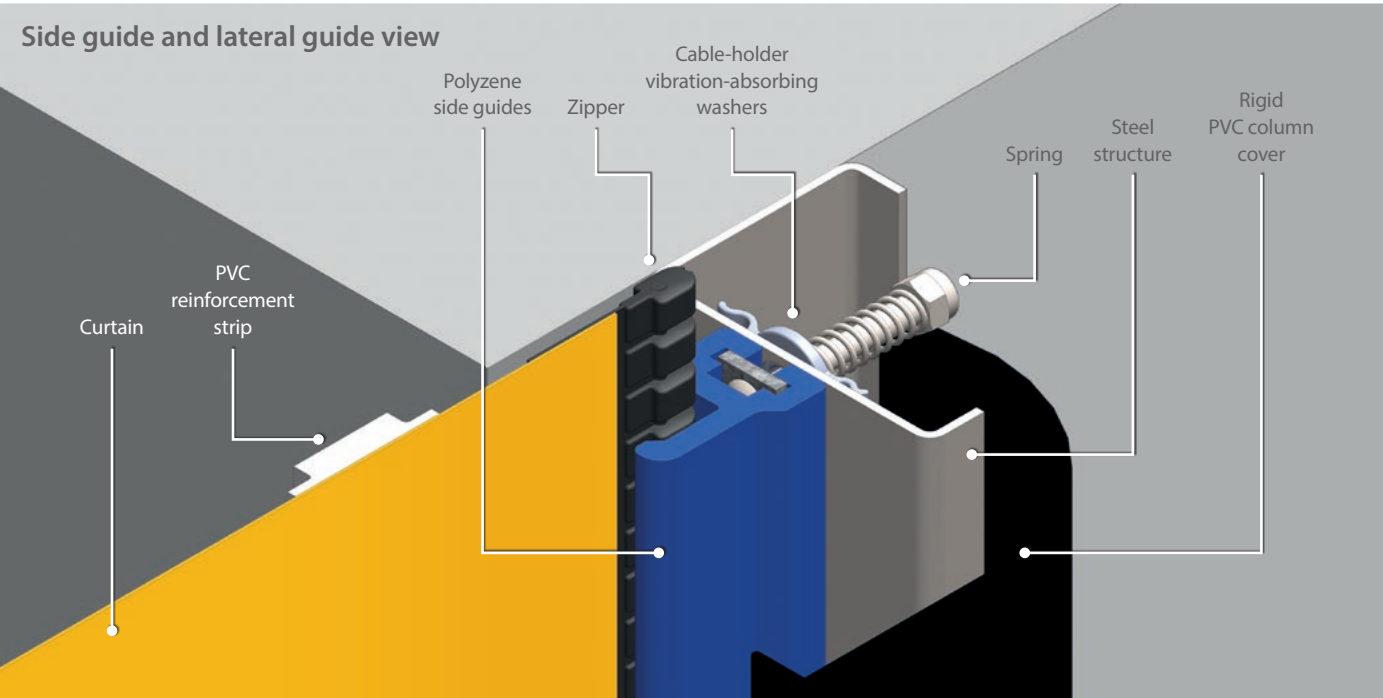

The Dynaco D-211 is a medium-performing high-speed roll-up door that is compact in size and features a fully flexible curtain and soft bottom edge, which make it easy to operate and provide excellent sealing. It's a self-reinserting door featuring a zipper curtain with "classic" reintroduction system.

Dynaco D-211 is an excellent choice for businesses that require a high-speed, space-saving, energy-efficient, and user-friendly door solution, with medium level of performance at an affordable price.

Why this is the right door for your business?

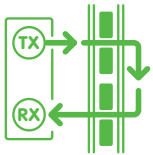

SLE

The unique, patented Safety Linear Encoder (SLE) detect possible obstacles and keep monitoring the position of the curtain during operations.



Energy-saving

All Dynaco high-performance doors are designed to deliver the best possible sealing properties and minimal opening/closing cycle. Their dynamic barrier significantly reduce energy costs.



Extremely safe

At Dynaco we never compromise on safety. All doors operate according to the highest safety standards, thanks to their soft bottom edge and our self-testing safety devices.



Uninterrupted workflow

Our high-performance doors are designed to guarantee continuous operation, no matter the traffic conditions.



Reduced maintenance cost

With technical features such as our self-reinserting system, soft bottom edge and our frequency converter technology, Dynaco doors help you keep maintenance at a minimum.



Environment control

Dynaco doors not only open but also close fast. Their opening time is minimal to avoid temperature fluctuations that may affect product quality.

Why Dynaco?



Automatic self-reinsertion

At Dynaco we invented the crash-forgiving, self-reinserting door. The one and only original. Its curtain automatically reinserts when dislodged, without intervention. This means: no repair costs, nor costly production downtime.



Frequency converter

Dynaco doors operate with the most advanced drive unit in the industry. The combination of a frequency-driven motor and encoder offer smooth operation and reliability. Any wearable elements are reduced to a minimum.



Sleek, attractive design

Our doors' compact, sleek and minimalist design fits perfectly in any type of building architecture.



Comfort of use

Dynaco doors are suited to a wide range of applications. Thanks to our different opening options and certified safety-devices, you are safe whenever you cross a Dynaco door.



Certified performance

Performance of all Dynaco doors has been tested and certified by a third-party notifying body.



Conform to EN norms

All Dynaco doors are completely conform to EN13241-1.



Dynaco offers a wide range of products for several industrial applications.
Find out more on www.dynacodoor.com.

D-211

ENTRY-LEVEL DOOR

Always ahead



Dynaco Europe NV
Waverstraat 21 B-9310 Moorsel-Aalst (Belgium)
Tel. +32 53 72 98 98 info@dynacodoor.com
www.dynacodoor.com

About Dynaco

Dynaco is the world leader in high speed door technology. It offers state of the art solutions for both commercial and industrial applications, including sectional overhead doors.

Founded in 1987, Dynaco has acquired an extensive expertise in high performance doors. Yet it continues to invest in order to exceed your expectations of quality and performance. A network of certified and dedicated partners ensures an optimal service to customers all over Europe.

Dynaco is part of the ASSA ABLOY Group, the world leader in access solutions. Every day, we help billions of people experience a more open world.